



JLG[®]

JLG[®] Telehandlers



JLG® Telehandlers

Meet Your Tough Telehandler Lineup.

Your productivity is on the line the minute you climb into the telehandler cab. The lineup of JLG® all-wheel steer telehandlers gives you all the power, reliability and maneuverability you've come to expect from a world-leading equipment manufacturer. With capacities from 5,500 to 12,000 lb and heights up to 55 ft, you can handle any job site challenge with these pick and place telehandlers. From commercial and residential construction to steel work and framing, JLG telehandlers can get you around crowded work areas to get the job done.

Single joystick controls provide easier boom positioning while a wide variety of attachments help you jump into new lifting challenges in seconds. Think of your JLG telehandler as a productivity tool with the ability to bring the job within reach. Backed by the industry's best service, parts and support. So your productivity is always at its peak. Job after job.

Your day won't seem so tough or your loads so heavy—if you let the power of JLG do the heavy lifting.



***"I love this machine —
it's central to everything
we do on the job site."***







FEATURES

Versatile Attachments

Choose from a wide range of attachments to keep productivity high, such as swing carriages and fork-mounted work platforms.



Ultra-Strong Boom

Lift higher and farther with more confidence with a boom strong enough to handle heavy application work.





Our attachments add to the versatility you need for whatever tasks are lined up for the day.



Our telehandlers are manufactured and designed to the highest standards of quality.

“If you want a machine that just keeps on going—this is it.”

Equipment You Can Count On.

We know that when you're on the job, you need machines that are going to stand up to the challenges of the day. That's why our equipment is manufactured to the highest standards and has some of the highest resale values in the industry. Because downtime is simply not an option. JLG is dedicated to providing high-performing, quality equipment you can rely on day after day.



Side-Mounted Engine

Combined with a high boom pivot and large cab, you've got better visibility.



Three Steering Modes

Front wheel, all-wheel and crab steer improve maneuverability around the job site.



Reach New Levels of Control and Comfort.

Your job becomes easier when you have a clear view of the job site. The engine position, boom pivot and cab position make for better visibility. While cab-mounted controls, a wrap-around dashboard and easy-to-read gauges let you know exactly what you're doing and where you need to be.

Designed with the operator in mind, the spacious cab with suspension seat allows the operator to work in comfort, which results in greater productivity.



Large Cab

With a wide cab, adjustable seating and 360-degree visibility, you'll be placing loads in greater comfort.



Single Joystick

Control boom lift and crowd for more precise positioning.

More Power for More Performance.

JLG engines and powershift transmissions deliver the horsepower, speed and control you need for optimum performance. You can lift and place heavy loads with confidence, knowing your telehandler will get you there. The side-mounted engines are easily accessible, helping to cut down on service and maintenance time.



A robust powertrain makes traversing uneven terrain a breeze.



Fuel-Efficient Tier 4i Engine

JLG® telehandlers feature Tier 4i engines, which not only provide a higher level of fuel efficiency, but also reduce the impact on the environment.



Drivetrain

Equipped with transmissions and axles that provide efficient control and durability while traveling around the job site.

Test-Driven. Job Site Proven.

Our commitment to engineering and testing means that our telehandlers provide you with high performance when you need it most.

Our modern test facility is designed to provide the most realistic construction environment possible. Advanced reach and load placement technologies are tested and refined to improve capacity, boom speed and accuracy.

Steering and drive performance are tested on the limestone steering course and in fording our mud pit. Durability and extended driving are tested using our crosstie, pothole and high speed roading courses. Our engineers and technicians conduct these tests, and more, so they understand what you're experiencing on the job site.





All Access for All Conditions.

JLG® telehandlers let you conquer the job site and work around obstacles, thanks to the three distinct steering modes that allow you to maneuver crowded areas. Drive over varied terrain with greater ease. With up to 19 inches of ground clearance, you've got more room to travel over debris. A 144-inch turning radius, on the G6-42A and G9-43A, makes navigating tight areas less challenging. So you can maneuver your way to the most productive day possible.

CHOOSE YOUR STEERING MODE



Front wheel steer when driving on the road.



All-wheel steer to help reduce the turning radius in confined areas.



Crab steer for sideways movement and precise positioning before lifting.

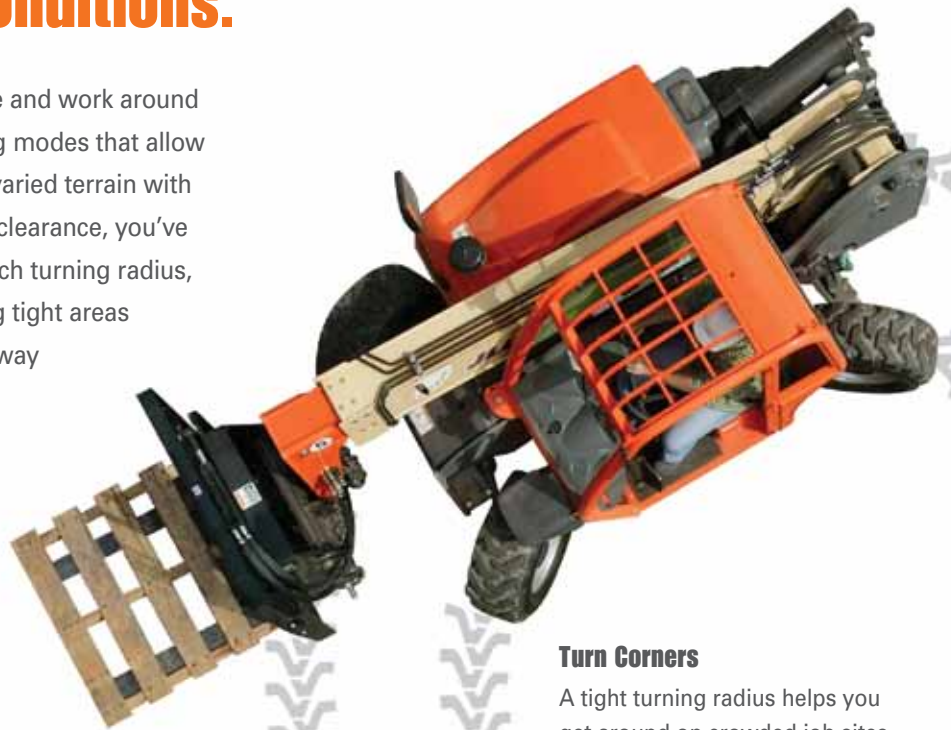

Turn Corners

A tight turning radius helps you get around on crowded job sites.

“JLG telehandlers give you maximum productivity in the toughest conditions.”

Real Confidence.

The solid overall design of these telehandlers means you can depend on them to carry loads up to 5,000 lb capacity at maximum lift height, and still have enough power to handle the biggest jobs. Greater stability results in greater operator confidence. No matter what your task or application, you can trust that our telehandlers will help you reach greater heights of performance.



Increase your productivity with lift heights ranging from 18 ft to 55 ft.





Enclosed Cab



Hitches†



Air Ride Seat†



Rotating Beacon



Pintle Hook*



2nd Auxiliary Hydraulics†



Molded Floor Mat†



Radio Ready Kit†



Tilt Steering†



Fenders



Brick Guard



Air Conditioning



Road Lights



Work Lights



*Not available on the G5-18A. † Available on the G5-18A only.

Firestone Tires Last Longer

JLG® telehandlers are exclusively equipped with Firestone DuraForce MH tires. Less susceptible to sidewall damage, the new Firestone tires last up to 3 times longer than the Firestone SGG telehandler tires and lower your cost of ownership. And because they're available in unique sizes, there are fewer parts to stock—resulting in reduced inventory carrying costs. The Firestone DuraForce MH tires are also available for your existing fleet.



ADVANTAGES

- Lasts up to 3 times longer than the Firestone SGG telehandler tires
- Lower profile minimizes the opportunity for sidewall damage
- Unique self-cleaning tread design enhances terrainability
- Fewer assembly combinations reduce inventory carrying costs
- Backed by Firestone's industry-leading support

Contact your JLG Distributor or JLG Sales Representative for more information.



A self-cleaning tread pattern provides lower ground bearing pressure to optimize performance in rough terrain.





Standard Carriage

Forks that are fully floating and adjustable side-to-side for efficient load entry and exit.



Material Bucket

Clean up the job site, spread gravel or for loading and leveling.



Side-Tilt Carriage

Allows for minor lateral positioning of the load during final placement.



Grapple Bucket

Features a hydraulic grapple arm to assist in job site cleanup.



Swing Carriage

Allows for greater versatility in moving and placing materials in confined areas or when exact positioning is required.



Side-Shift Carriage

Four inch left and right carriage shift allows for precision load placement.



Dual Fork Positioning Carriage

Provides the ability to adjust the position of each fork independently, allowing the operator to handle a variety of palletized loads without having to leave the cab.



Truss Boom

Allows operator to set trusses and wall sections for wood and steel building construction. Available with or without winch.



Pallet Forks

Rugged design makes it easier to handle heavy palletized material.



Fork-Mounted Work Platform

Extend the capabilities of your telehandler and get more work done by lifting material and persons to working heights.



Lumber Forks

Wider width provides a larger surface area for stability when transporting longer material.



Lifting Hook

Add versatility to any standard carriage by lifting and lowering objects without changing attachments.



Cubing Forks

Allows operator to load, unload and place cubes of brick and block with ease.



Fork Extensions

Fork extensions provide additional support to lift large or long objects. They are made with heavy duty steel and a pin is used to secure them to the existing telehandler forks.

Our full range of attachments extends the versatility and performance of your telehandler, so you can handle an even wider variety of jobs faster and with greater ease.

Not all options and attachments may be available for all models. Photographs are representative of attachments and options. JLG reserves the right to make modifications without prior notification.



Putting Your Work Above Everything.

When it comes to JLG® Ground Support, it's all about you. Your productivity. Your profitability. Your uptime. From the purchase of your first piece of equipment straight through to the training, parts and maintenance that follows.



■ Customer Service Call Center

You can be assured we'll be giving an all-out effort to support you. Just think of us as your personal on-call, full-service support team. We make it happen. Period.

■ Financial Solutions

Maximizing your profits. Preserving your cash flow. Let our financing specialists help choose the program designed specifically for your needs.

■ Aftermarket Parts

Keep your equipment running at peak performance with genuine replacement parts, accessories, attachments, rebuilt and competitive parts all from one source—JLG.

■ Training

Knowing your equipment inside and out results in higher productivity on the job. Our instructor-led courses give you the hands-on time you need for success.

■ Service Centers

Your needs. Your uptime. JLG is on the job to fulfill your every need, from repair, reconditioning, same-day parts and much more. We're here to support you.

	G5-18A	G6-42A	G9-43A	G10-43A	G10-55A	G12-55A
Rated Capacity @ 24 in. (610 mm) Load Center	5,500 lb (2,495 kg)	6,600 lb (2,994 kg)	9,000 lb (4,082 kg)	10,000 lb (4,536 kg)	10,000 lb (4,536 kg)	12,000 lb (5,443 kg)
Maximum Lift Height	18 ft 4 in. (5.49 m)	42 ft (12.8 m)	43 ft (13.11 m)	43 ft (13.11 m)	55 ft (16.76 m)	55 ft (16.76 m)
Capacity @ Maximum Lift Height	4,400 lb (1,996 kg)	6,000 lb (2,721 kg)	7,000 lb (3,175 kg)	*7,000 lb (3,175 kg)	*5,000 lb (2,268 kg)	*5,000 lb (2,268 kg)
Maximum Reach	10 ft 11 in. (3.33 m)	29 ft (8.84 m)	30 ft 6 in. (9.3 m)	30 ft 6 in. (9.3 m)	42 ft (12.8 m)	42 ft (12.8 m)
Capacity @ Maximum Reach	1,850 lb (839 kg)	1,000 lb (454 kg)	1,200 lb (544 kg)	*2,300 lb (1,043 kg)	*3,000 lb (1,361 kg)	*3,500 lb (1,588 kg)
Approximate Operating Weight	10,800 lb (4,899 kg)	20,400 lb (9,253 kg)	25,907 lb (11,751 kg)	26,801 lb (12,157 kg)	34,850 lb (15,808 kg)	35,860 lb (16,266 kg)
A. Length (Less Forks)	144.2 in. (3.66 m)	212.6 in. (5.4 m)	237 in. (6.02 m)	233 in. (5.9 m)	240 in. (6.1 m)	240 in. (6.1 m)
B. Width	71.5 in. (1.8 m)	97.2 in. (2.47 m)	97.2 in. (2.47 m)	98.2 in. (2.49 m)	101.3 in. (2.57 m)	101.3 in. (2.57 m)
C. Height	75.6 in. (1.9 m)	94 in. (2.39 m)	95.5 in. (2.43 m)	95.5 in. (2.43 m)	101 in. (2.57 m)	101 in. (2.57 m)
D. Wheelbase	90 in. (2.29 m)	128 in. (3.25 m)	132 in. (3.35 m)	132 in. (3.35 m)	144 in. (3.66 m)	144 in. (3.66 m)
E. Ground Clearance	10.8 in. (274 mm)	16.4 in. (417 mm)	19 in. (483 mm)	18 in. (457 mm)	18 in. (457 mm)	18 in. (457 mm)
Outside Turning Radius	126.0 in. (3.2 m)	144 in. (3.66 m)	144 in. (3.66 m)	144 in. (3.66 m)	168 in. (4.27 m)	168 in. (4.27 m)
Drive	4 x 4	4 x 4	4 x 4	4 x 4	4 x 4	4 x 4
Engine	Perkins 1104D	Cummins QSB3.3L ATAAC	Cummins QSB3.3L ATAAC	Cummins QSB3.3L ATAAC	Cummins QSB4.5L ATAAC	Cummins QSB4.5L ATAAC
HP @ RPM	84 hp @ 2,200 rpm	100 hp @ 2,400 rpm	100 hp @ 2,400 rpm	100 hp @ 2,400 rpm	130 hp @ 2,500 rpm	130 hp @ 2,500 rpm
Transmission	Hydrostatic	Powershift	Powershift	Powershift	Powershift	Powershift
Steering	All-Wheel	All-Wheel	All-Wheel	All-Wheel	All-Wheel	All-Wheel
Tires	12 x 16.5	370/75-28	370/75-28	400/75-28	400/75-28	400/75-28
Maximum Travel Speed	17 mph (27 kmph)	19.5 mph (31.4 kmph)	19.5 mph (31.4 kmph)	19.5 mph (31.4 kmph)	20 mph (32 kmph)	20 mph (32 kmph)
Frame Tilt Left/Right	—	±10 Degrees	±10 Degrees	±10 Degrees	±10 Degrees	±10 Degrees

*Outriggers are required to achieve stated capacity.

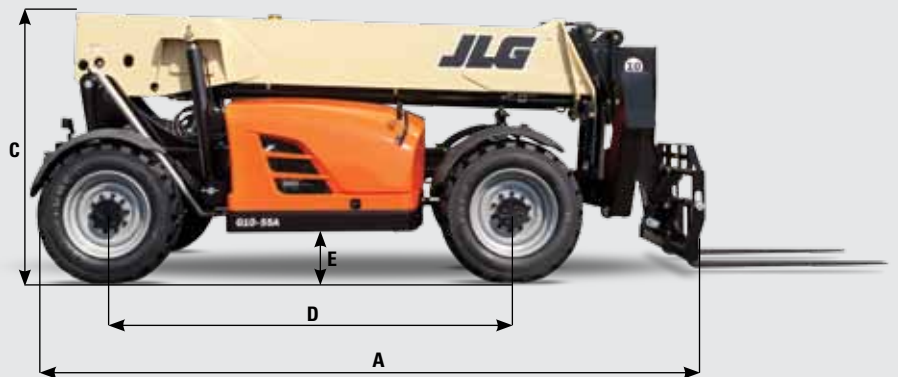
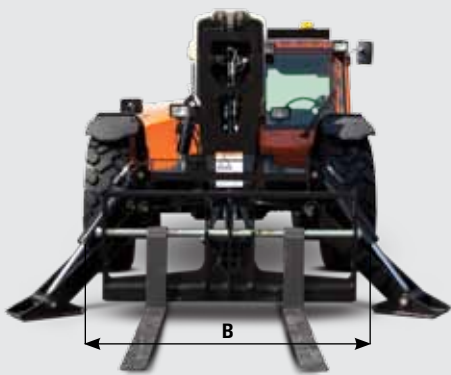

For complete specifications, visit www.jlg.com

Due to continuous product improvements, JLG Industries reserves the right to make specification and/or equipment changes without prior notification. These machines meet or exceed ANSI/ITSDF B56.6-2005 as originally manufactured for intended applications.

JLG Industries, Inc.
1 JLG Drive
McConnellsburg, PA 17233-9533
Telephone 717-485-5161
Toll-free in US 877-JLG-LIFT
Fax 717-485-6417
www.jlg.com
An Oshkosh Corporation Company

Form No.: JLG-TEL-BRO-0612
Part No.: 3131573
R081202
Printed in USA

